

SV500

Precision Dispensing Pump
Solenoid Operated, Piston Driven
Output/Stroke: 100 μ l to 1250 μ l (AC)



Valcor Dispensing / Metering Series



DESCRIPTION

The SV500 series dispensing pump is a solenoid operated piston driven pump that delivers a wide range of fluids with high precision. By combining the easily adjustable stroke of the pump with variable cycle rates, users have complete control of the volume and rate of dispense for specific applications. Wetted parts are stainless steel and Viton or EPDM, making this series suitable to handle a wide range of fluids.

APPLICATIONS

The SV500 series is a rugged construction suitable for a variety of dispensing applications such as the following:

- Adhesive or ink dispensing
- Reagents for analyzers or clinical instruments
- Water for humidification systems
- Lubricants for automated equipment
- Chemicals for pools & spas
- Syrup & Flavoring for soda machines
- Fragrance for personal products
- Analyzer sampling

FEATURES

- Adjustability over a wide range of operating conditions
- Volume output per stroke is adjusted by setting stroke
- Flow rate per minute is adjusted by frequency of operation
- Repeatability within 2%
- Self priming: can start dry and capable of lifting 6' of H₂O.
- Can handle fluid viscosity as high as 10,000 centistokes
- Maintenance free and long life
- Choice of elastomer; Viton or EPDM
- Built-in mounting bracket



VALCOR SV500 SPECIFICATIONS

Construction

Pump Parts in Contact with Fluid

Wetted Materials 300 / 400 Series SS, EDPM or Viton, Silver (AC)

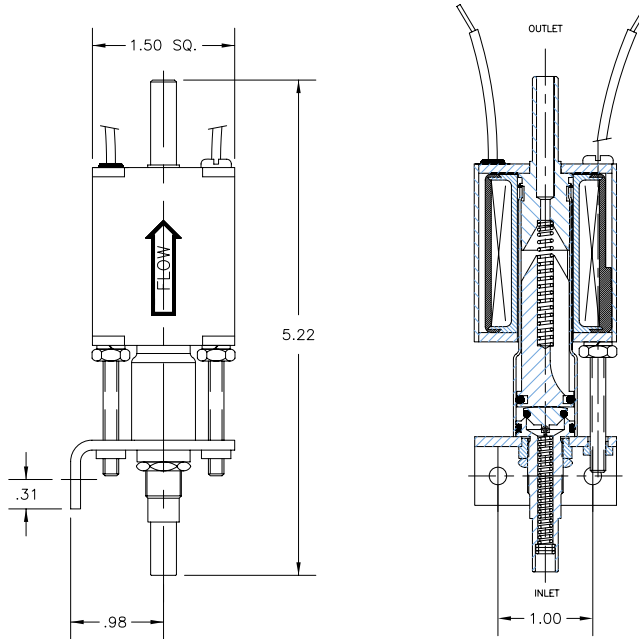

Electrical

Standard voltages 115/60 Hz or 24/DC. Other voltages are also available. Consult factory.

Standard coil housing General purpose with pigtail leads

Specifications

Precision Dispensing Pump

Tube Connection	1/4" ID flex tubing
Coil Construction	Class H, 10" Leads
Power	21 Watts (115/60), 21 Watts (24DC)
Output per Stroke	100 to 1250 μ l (AC) 100 to 1000 μ l (DC)
Max. Stroke per Minute	120 on H ₂ O
Max. Dispense Rate	180 ml/min (AC) 120 ml/min (DC)
Max. Priming Height	72" of H ₂ O
Minimum On-Time	250 milliseconds
Max. On-Time	1 second (AC) 6 seconds (DC)
Repeatability	\pm 2%
Special Requirements	Consult Factory

Part Number Configurator

Series Number	Lead Option	Voltage	Elastomer	Tube Connection size
SV500	P= Pigtails	94H = 115/60 Hz	2 = Viton	1 = 0.272" Dia. Tube
	C= Conduit	84 = 24/DC	7 = EPDM	2 = 0.250" Dia. Tube

Example: SV500P94H-7-1 equals SV500 pump with pigtail leads, 115/60 AC coil, EPDM elastomer and 0.272" diameter tube connection