

SV515

Precision Dispensing Pump
Solenoid Operated, Piston Driven
Output per Stroke: 3 μ l to 15 μ l

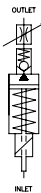

Valcor Dispensing / Metering Series



DESCRIPTION

The SV515 series dispensing pump is a solenoid operated piston driven pump that delivers a wide range of fluids with high precision. By combining the easily adjustable stroke of the pump with variable cycle rates, users have complete control of the volume and rate of dispense for specific applications. Wetted parts are stainless steel and Viton or EPDM, making this series suitable to handle a wide range of fluids.

APPLICATIONS

The SV515 series is a rugged construction suitable for a variety of dispensing applications such as the following:

- Adhesive or ink dispensing
- Reagents for analyzers or clinical instruments
- Water for humidification systems
- Lubricants for automated equipment
- Chemicals for pools & spas
- Syrup & flavoring for soda machines
- Fragrance for personal products
- Analyzer sampling

FEATURES

- Adjustability over a wide range of operating conditions
- Volume output per stroke is adjusted by mechanically setting stroke
- Flow rate per minute is adjusted by frequency of operation
- Repeatability within 2%
- Self priming: can start dry and capable of lifting 3' of H₂O.
- Can handle fluid viscosity as high as 10,000 centistokes
- Maintenance free and long life
- Choice of elastomer; Viton or EPDM



VALCOR SV515 SPECIFICATIONS

Construction

Pump Parts in Contact with Fluid

Wetted Materials 300 / 400 Series SS, EDPM or Viton

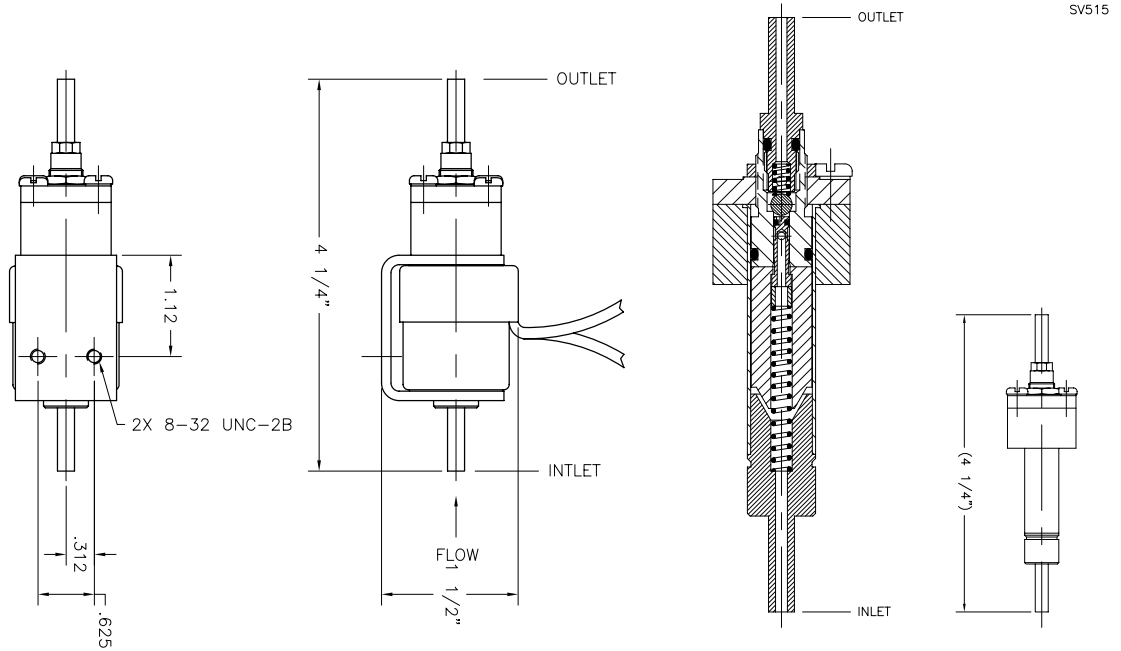

Electrical

Standard voltages	24/ DC Other DC Available
Standard coil housing	Open frame with flying leads

Specifications

Precision Dispensing Pump

Tube Connection	3/16" ID flex tubing
Coil Construction	Class B, 18" Leads
Power	7 Watts (24DC)
Output per Stroke	3 to 15 µl
Max. Stroke per Minute	120 on H2O
Max. Dispense Rate	3 ml/min
Max. Priming Height	36" of H2O
Minimum On-Time	50 milliseconds
Max. On-Time	6 seconds
Repeatability	±2%
Repeatability	±2%
Special Requirements	Consult Factory

How to specify part numbers

Part Number	Description
SV515A197-2	SV515 pump with 24/DC coil and Viton Elastomer
SV515A197-7	SV515 pump with 24/DC coil and EPDM Elastomer

NOTE: Other voltages are also available. Consult factory.