

Pulse Relay

83939-C 1

GENERAL DESCRIPTION

The No. 83939-C1 Pulse Relay is a two-way, diaphragm-actuated, non-venting, normally open valve. Its design is such that after being pressurized and closed, it will not reopen when pressure is lost at Port 1 unless pressure is also lost at Port 2, or a pressure is introduced at Port 3 to blow the poppet off seat. Also, it has a connection which may be used to cancel the actuating pressure at Port 1.

SPECIFICATIONS

Construction: Aluminum body; stainless steel cover, bracket, and springs; elastomer coated fabric diaphragms and gaskets; stainless steel and aluminum valve with resilient seat.

Supply Pressure: See Figure 2.

Maximum Pressure: See Figure 2.

CAUTION: DO NOT EXCEED MAXIMUM PRESSURES

Mounting: Surface

Dimensions: See Figure 1

Connections: 1/8"-27 NPT

Approximate Shipping Weight: 12 Oz. (.340 kg)

ORDERING INFORMATION:

Specify: No. 83939-C1

INSTALLATION

A. General

Tubing and fittings used to connect the relay must be free of chips, dirt and moisture or other foreign material.

It is recommended that an "anti-seize" type thread compound be applied to the second or third male thread in moderate amount. Do not allow compound to be deposited inside the relay. Thread sealing tape is not recommended.

For continuous, trouble-free operation, the supply to the relay must be clean and dry.

B. Mounting

When installing the No. 83939-C1 Pulse Relay, care should be taken to prevent any foreign matter from entering the ports. Provisions should be made to prevent foreign matter from entering the ports which are left open to the atmosphere.

The relay may be installed in any position, but vertical (upright) is recommended. The relay should be securely mounted, using the two slots (clearance for No. 10 screws), provided in the mounting bracket (See Figure 1).

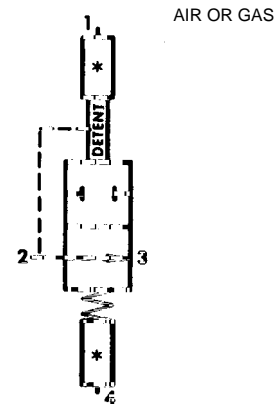
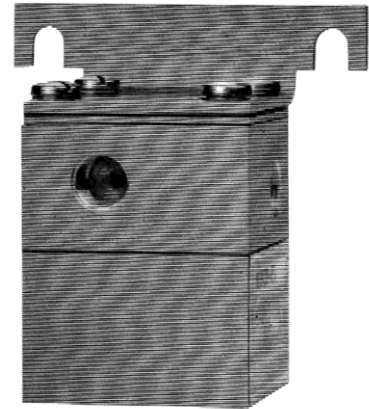

J. I. C. Symbol

DIMENSIONS

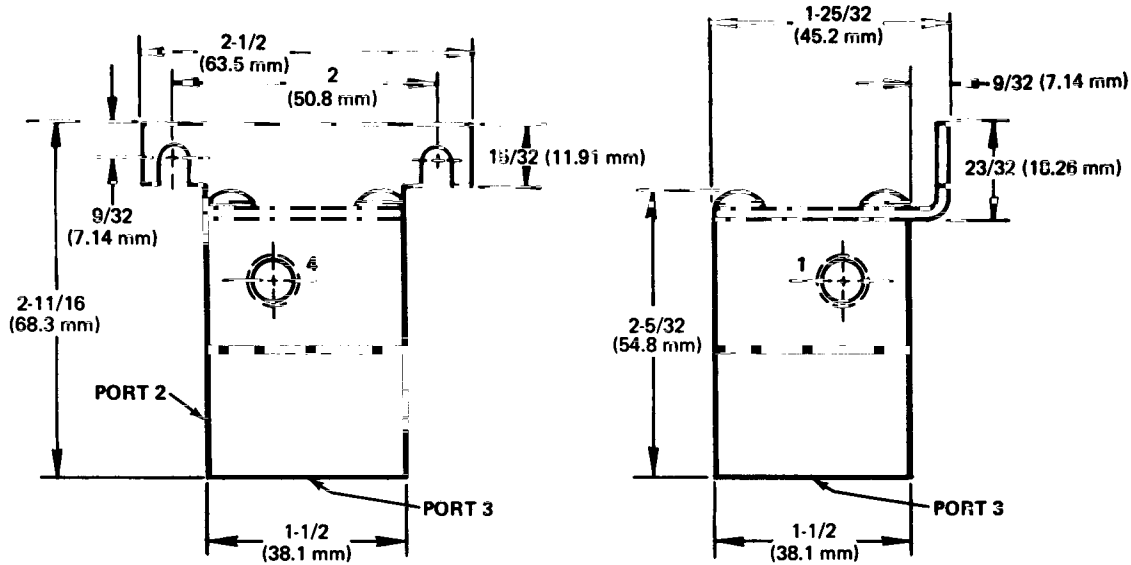

Figure 1

OPERATION

With no pressure applied to the diaphragm through Port 1, Port 2 is connected through this normally open relay to Port 3.

When sufficient pressure is applied to the diaphragm through Port 1, the stem moves down and forces the lower poppet on seat, closing Port 3 to Port 2. Subsequent loss of pressure at Port 1 will allow the stem to return to its original position. However, since the stem is not mechanically connected to the lower poppet, the poppet will

remain on seat (provided pressure was lost at Port 3 with the closing of the relay) due to the unbalanced pressure across the poppet.

In order to reopen the relay, pressure must be removed from Port 2, which will relieve the unbalanced pressures on the lower poppet, allowing it to return to its original open position, or pressure applied through Port 3 will force the poppet off seat. Also, Port 1 pressure may be cancelled by applying an equalizing pressure to Port 4.

NOTE: Graph A indicates pressure (Port 3) required to open valve at various supply pressures (Port 2) with no actuating pressure (Port 1) or equalizing pressure (Port 4)

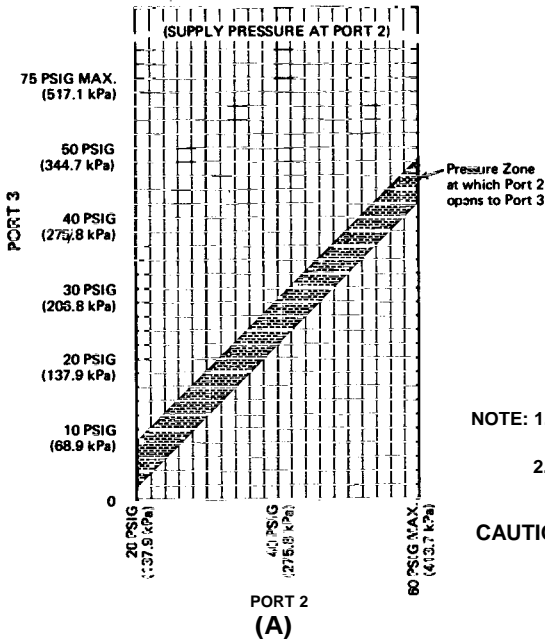

NOTE: Graph B indicates decreasing actuating pressure (Port 1), with valve closed, required to permit the diaphragm stem to lift off the lower poppet at various supply pressures (Port 2). Also, Graph B indicates decreasing actuating pressure (Port 1) minus equalizing pressure (Port 4) to permit same action at the various supply pressures (Port 2).

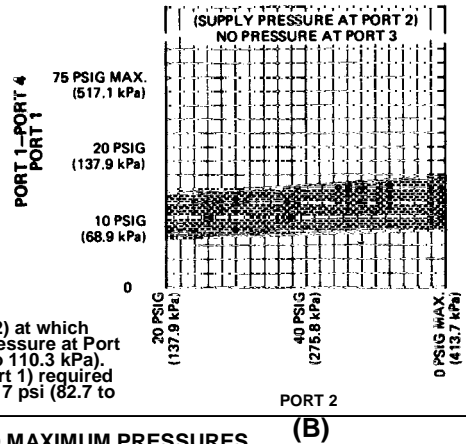

NOTE: 1. Supply pressure (Port 2) at which valve opens with no pressure at Port 3 is 14 to 16 psi (96.5 to 110.3 kPa).
2. Actuating Pressure (Port 1) required to close valve is 12 to 17 psi (82.7 to 117.2 kPa).

CAUTION: DO NOT EXCEED MAXIMUM PRESSURES.

Figure 2

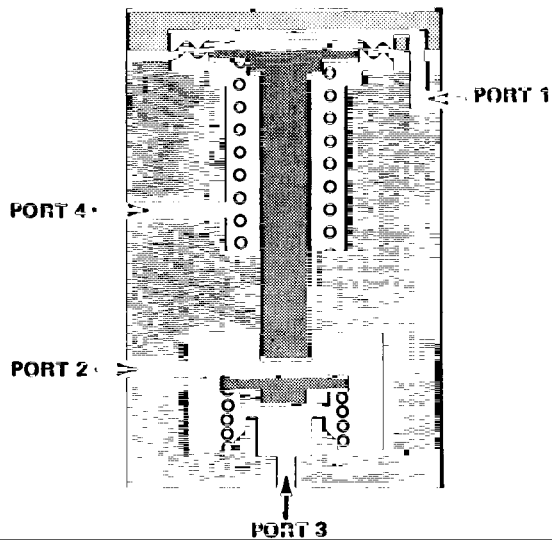

Figure 3

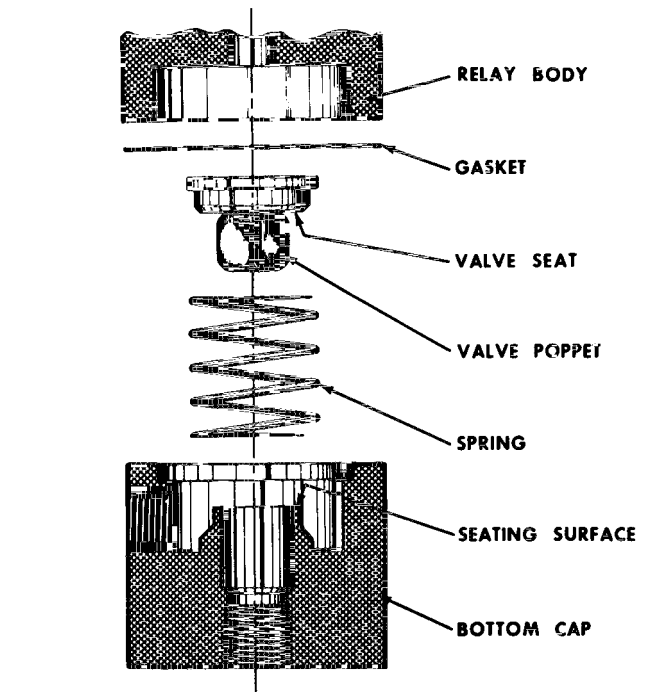

Figure 4

MAINTENANCE

WARNING: Disassemble carefully - spring load forces present.

- A. If excessive leakage occurs at valve seat, disassemble the relay. Clean poppet and seat with soft, dry cloth (See Figure 4).
- B. If relay does not function properly due to contamination by foreign matter, disassemble and clean all metal parts with non-flammable solvent and dry thoroughly.
- C. After reassembly, check for external leakage. Retighten assembly screws as necessary. Gasket cement should not be used to seal leaks due to the possibility of plugging small passages or damaging the operating characteristics of the diaphragms.

CAUTION:

If cleaning is required, do not subject "O" rings, valve poppets, diaphragms or gaskets to cleaning fluid, acetone or any halogenated hydrocarbons such as vapor degrease liquids, etc. Clean only with a soft, dry cloth.

Upon reassembly, all "O" rings are to be lubricated with a silicone-type lubricant. Do not permit lubricant to get on poppet or valve seats.

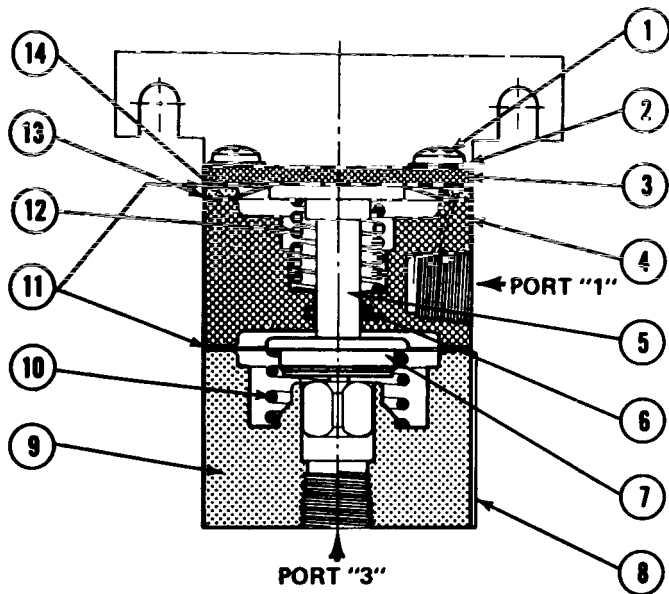
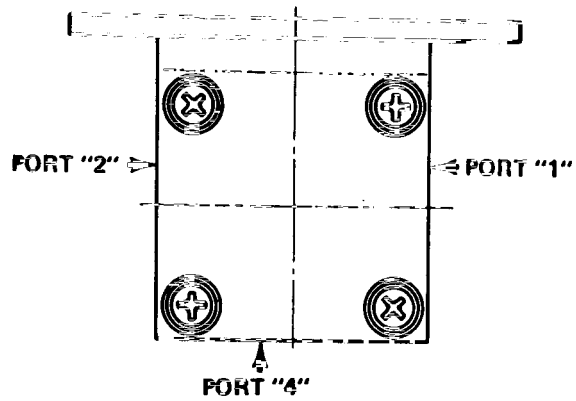

PARTS LIST

DET NO	REQ'D	DESCRIPTION	DWG. NO.
1	4	Screw	33713-E2409
2	4	Lockwasher	36600-L0609
3	1	Mounting Bracket	24637-C2
4	1	Relay Body	31857-E1
5	1	Head & Stem Assy	85013-B 1
6	1	O-Ring	36240-C10
7	1	Plug & Guide Assy	99264-B1
8	1	Nameplate	30036-G 1
9	1	Relay Body	31857-D1
10	1	Spring	25121-A1
11	2	Gasket	33665-B 1
12	1	Spring	26148-A1
13	1	Diaphragm	24498-A1
14	1	Spacer	33430-A1

NOTE: For complete kit containing all "O" Rings, gaskets, diaphragms, and poppet to service one unit, order Repair Kit No. 82665-B3.

Schneider
Electric Systems USA, Inc

1602 Mustang Dr
Maryville, TN 37801
Ph (865) 981-3100
FX (865) 981-3168