

High Capacity Relay with Internal Orifice

83939-D Series

GENERAL DESCRIPTION

The 83939-D Series is a high capacity, two-position, four-ported, 3-way, normally closed diaphragm-actuated relay. This relay will supply pressure from Port S to Port C when the actuating diaphragm is pressurized. When the relay is in the closed position, it will vent downstream pressure. These relays have no transient position which allows Ports S, C, and V to all be connected; i.e., before Ports S and C are connected, Port V will be closed, and likewise, before Ports V and C are connected, Port S will be closed.

SPECIFICATIONS

Construction: Aluminum body; stainless steel cover, bracket and springs; elastomer coated fabric diaphragms and gaskets; stainless steel and aluminum valve with resilient seat.

Supply Pressure:See Figure 3

Maximum Pressure:See Figure 3

CAUTION: DO NOT EXCEED MAXIMUM PRESSURES.

Mounting:Surface

Dimensions:See Figure 1.

Models Available:

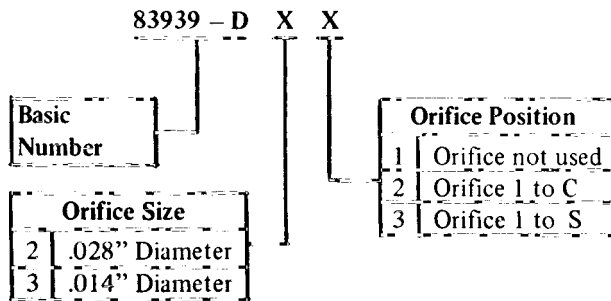

Connections: 1/4"-18 NPT

Approximate Shipping Weight:2 lb. (.907 kg.)

ORDERING INFORMATION:

Specify Model Number

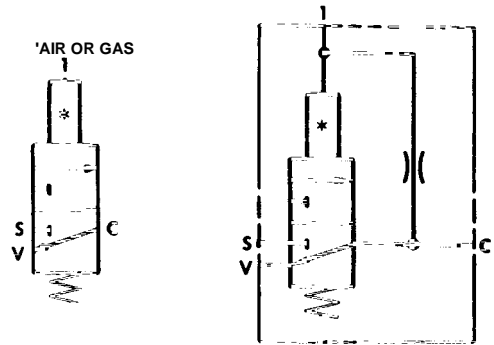
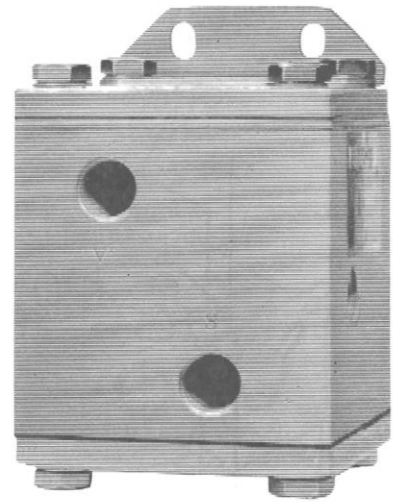

83939-D21, D31

83939-1322, D32

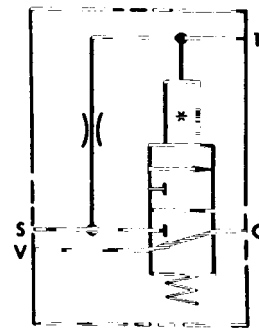

83939-D23, D33

J. I. C. Symbols

INSTALLATION

A. General

Tubing and fittings used to connect the relay must be free of chips, dirt, and moisture or other foreign material.

It is recommended that an "anti-seize" type thread compound be applied to the second or third male thread in moderate amount. Do not allow compound to be deposited inside the relay. Thread sealing tape is not recommended.

For continuous, trouble-free operation, the supply to the relay must be clean and dry.

B. Mounting

When installing the No. 83939-D Series Relay, care should be taken to prevent any foreign matter from entering the ports. Provisions should be made to prevent foreign matter from entering the ports which are left open to the atmosphere.

The relay may be installed in any position, but vertical (upright) is recommended. The relay should be securely mounted, using the two slots (clearance for No. 10 screws), provided in the mounting bracket (See Figure 1).

DIMENSIONS

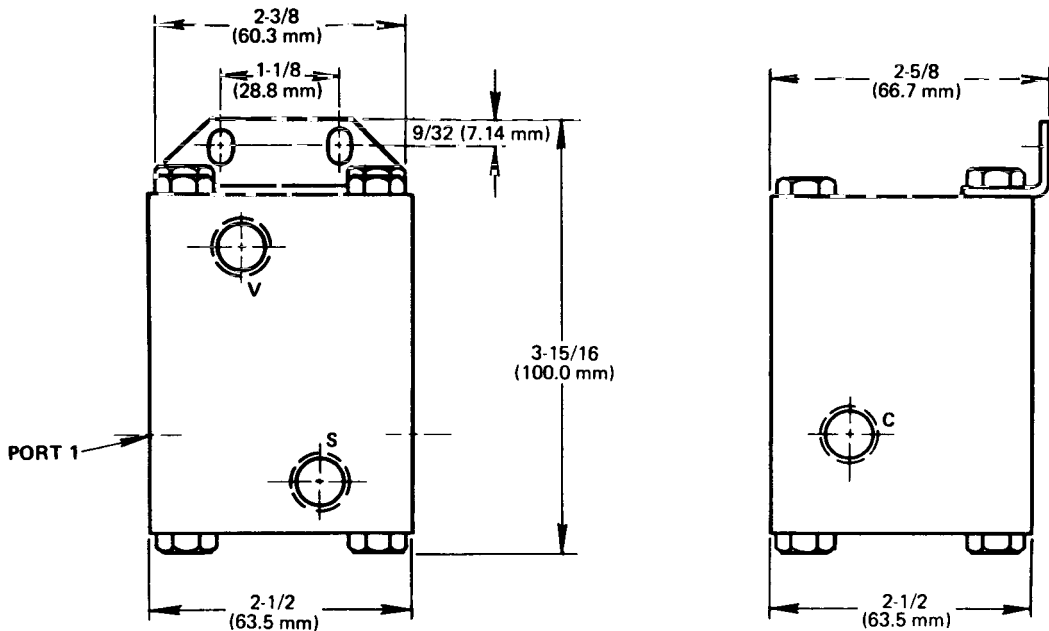

Figure 1

OPERATION

With no pressure applied to the diaphragm through Port 1, Port C is connected through a hollow stem to Port V while closed to Port S (supply port).

When sufficient pressure is applied to the diaphragm through Port 1, the hollow stem moves down, closing Port C to Port V. As the hollow stem moves farther, it forces the lower poppet down opening Port S to Port C.

Loss of the pressure at Port 1 will allow the hollow stem to return to its original position. This allows the spring and the supply pressure to push the lower poppet to its original position. Port S is now closed to Port C while Port C is connected to Port V.

The 83939-D22 and 83939-D32 have an internal orifice assembly which connects Port 1 to Port C. The 83939-D23 and 83939-D33 have an internal orifice assembly which connects Port 1 to Port S.

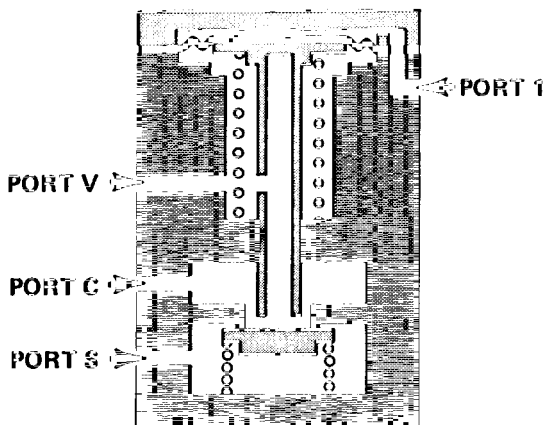
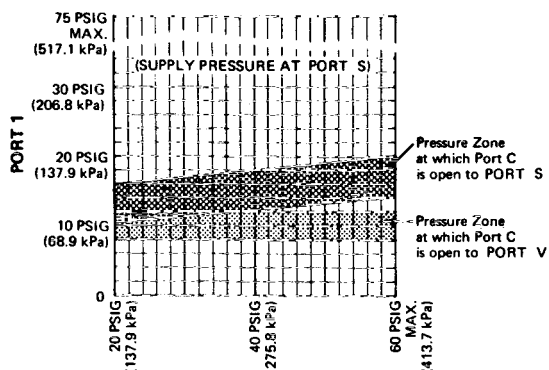

Figure 2

NOTE: Graph below indicates actuating pressure (Port 1) required to operate valve at various supply pressures (Port S).



PORT S
CAUTION: DO NOT EXCEED MAXIMUM PRESSURES.

Figure 3

MAINTENANCE

WARNING: Disassemble carefully - spring load forces present.

- A. If excessive leakage occurs at valve seat, remove bottom cover. Clean poppet and seat with soft, dry cloth (See Figure 4).
- B. If relay does not function properly due to contamination by foreign matter, disassemble and clean all metal parts with non-flammable solvent and dry thoroughly.
- C. The orifice is removable by applying pressurized air to Port I. **WARNING:** The pressure should be initially applied at 3 psi (20.7 kPa) and slowly increased to a maximum of 30 psi (206.8 kPa). Care must be exercised to prevent the orifice from being ejected in a manner which would be injurious to personnel. Clean with a small diameter wire and pressurized air. In removal or replacement of orifice, care must be exercised not to nick or scratch sealing surfaces. "O" ring must be inserted into relay body before orifice.

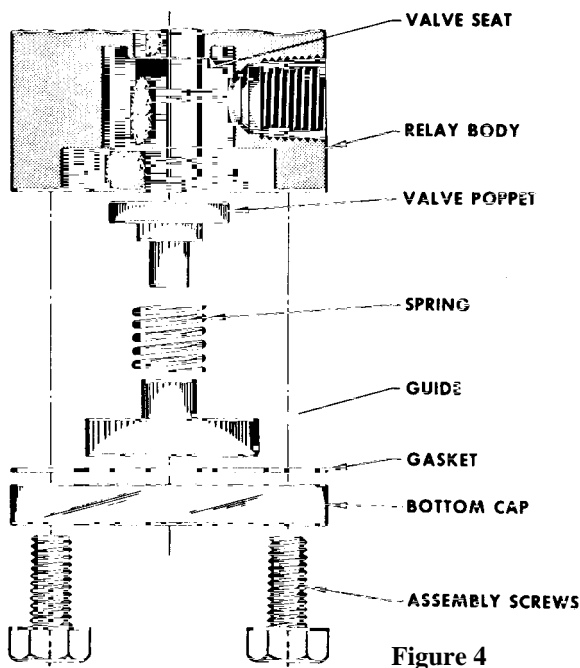

Figure 4

D. After reassembly, check for external leakage. Retighten assembly screws as necessary. Gasket cement should not be used to seal leaks due to the possibility of plugging small passages or damaging the operating characteristics of the diaphragms.

CAUTION:

If cleaning is required, do not subject "O" rings, valve poppets, diaphragms or gaskets to cleaning fluid, acetone or any halogenated hydrocarbons such as vapor degrease liquids, etc. Clean only with a soft, dry cloth.

Upon reassembly, all "O" rings are to be lubricated with a silicone-type lubricant. Do not permit lubricant to get on poppet or valve seats.

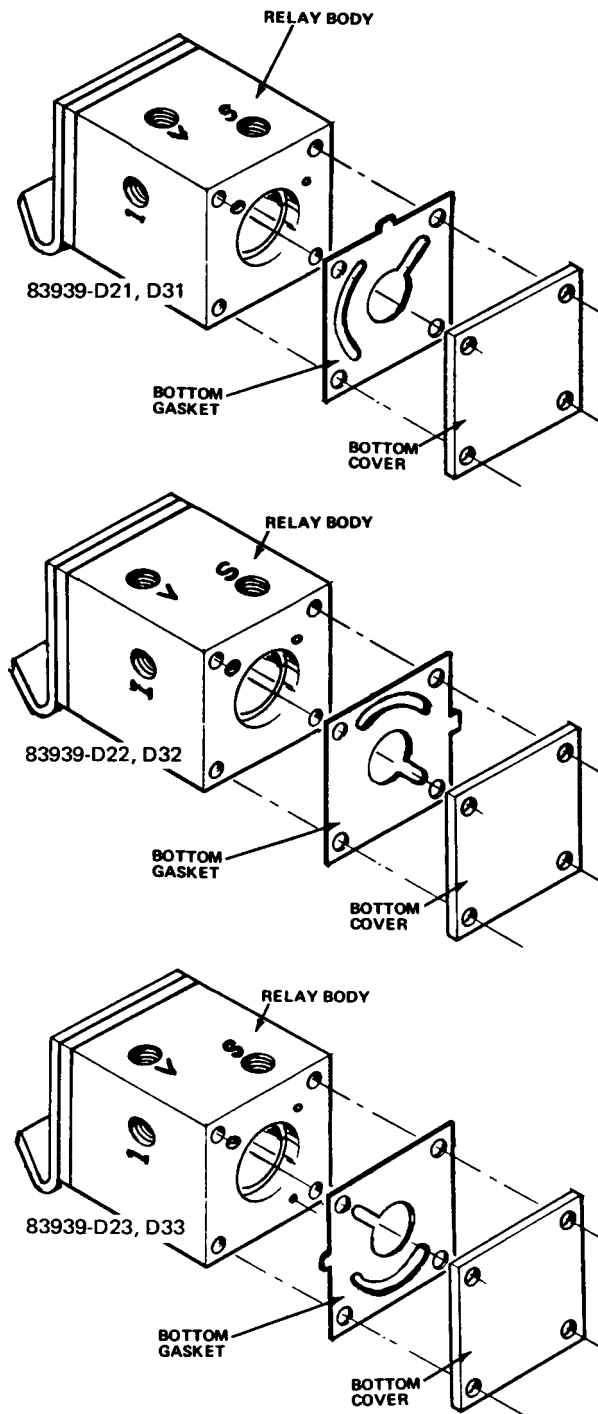
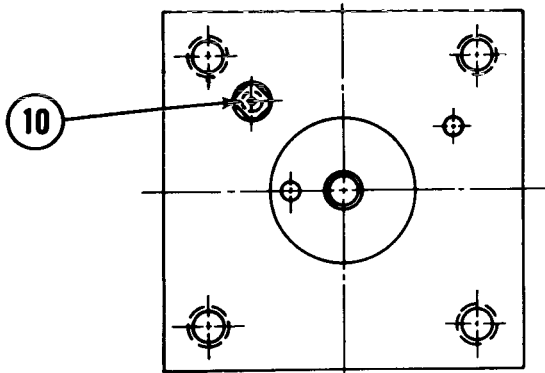
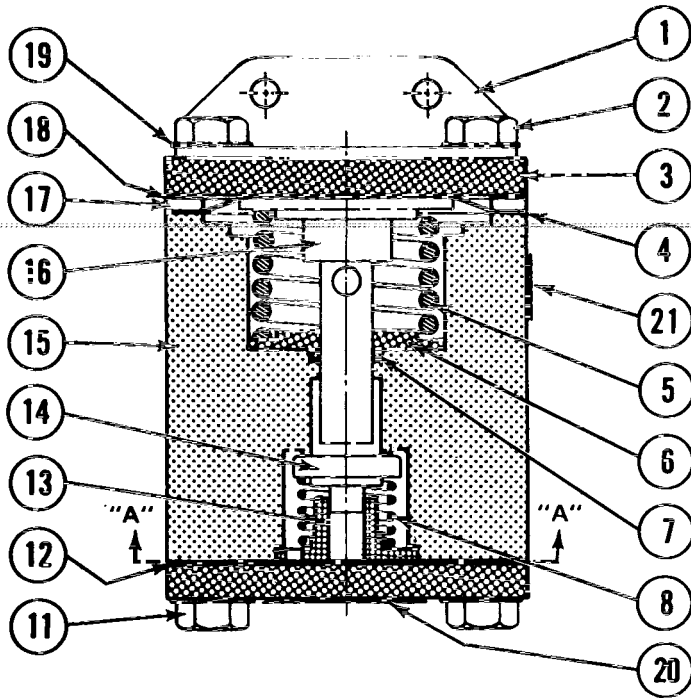

Figure 5

PARTS LIST



VIEW "A-A"

PARTS LIST

| DET. NO. | NO. REQ 'D | DESCRIPTION | DRAWING NO. |
|----------|------------|----------------------|----------------|
| 1 | 1 | Mounting Bracket | 24637-A4 |
| 2 | 2 | Screw | 36618-E1709 |
| 3 | 2 | Cover | 33666-B1 |
| 4 | 1 | Diaphragm | 24498-C1 |
| 5 | 1 | Spring | 24616-A1 |
| 6 | 1 | Spring Seat | 33669-B1 |
| 7 | 1 | O-Ring | 36240N2012 |
| 8 | 1 | Spring | 33668-A1 |
| 10 | 1 | Orifice | See Tabulation |
| 11 | 6 | Screw | 36618-E1509 |
| 12 | 1 | Gasket | 33665-C1 |
| 13 | 1 | Plug Guide | 24607-B 1 |
| 14 | 1 | Plug Assembly | 84980-B1 |
| 15 | 1 | Relay Body | 31857-F1 |
| 16 | 1 | Head & Stem Assembly | 85013-D1 |
| 17 | 1 | Spacer | 33430-C1 |
| 18 | 1 | Gasket | 33665-D1 |
| 19 | 8 | Washer | 36600L0909 |
| 20 | 1 | Decal | 35173-B1 |
| 21 | 1 | Nameplate | 30036-G2 |

* Detail 12 should be assembled as shown in Figure 5.

TABULATION

| ASSEMBLY NO. | DET.10 |
|--------------|----------|
| 83838-D21 | 31311-F3 |
| 83838-D22 | |
| 83838-D23 | |
| 83838-D31 | 31311-F4 |
| 83838-D32 | |
| 83838-D33 | |

NOTE: For complete kit containing all 'O' Rings, gaskets, diaphragms and poppet to service one unit, order Repair Wt No. 82665-82.

Schneider
Electric Systems USA, Inc

1602 Mustang Dr
Maryville, TN 37801
Ph (865) 981-3100
FX (865) 981-3168