

Flow Control Valve No. 99363-A1

GENERAL DESCRIPTION

The No. 99363-A1 Flow Control Valve provides a controlled rate of flow in one direction and full flow in the reverse direction. Adjustment of flow can be made under pressure and is not affected by vibration.

SPECIFICATIONS

Construction:..... Brass body; stainless steel needle, spring, and ball; Delrin ball follower; Teflon* washer seal with plated steel retainer. Nylon adjustment knob and locknut.

Supply Pressure: 200 psi maximum between -40 to +212 F.
CAUTION: DO NOT EXCEED MAXIMUM PRESSURE/TEMPERATURE RATING.

Connections: 1/8" NPT (female) both ends.

Dimensions: See Figure 1.

*Registered trademark of E. I. DuPont Company



INSTALLATION

When installing the No. 99363-A1 Flow Control Valve, care must be taken to prevent any foreign matter from entering the port. Install valve in line with metered flow in direction of arrow on side of valve.

ADJUSTMENTS

First, select the stem color or number of the desired flow. Then, accurately set with the micrometer numbers on the bright yellow knob; align the knob number with the inscribed mark on the valve body (valve may be adjusted within 1 /20 of a turn when adjusting the knob between numbers). EXAMPLE: When the valve is set at 1 (WHITE) .7, it reads 1.7. When the valve is set at 3 (ORANGE) .4, it reads 3.4.

Finally, turn the blue locknut clockwise to prevent unwanted changes in setting. For future reference, record the stem color, stem number, and the knob number; you have the same setting every time.

WARNING: An estimated eight percent of the population is color blind.



J.I.C. SYMBOL

ORDERING INFORMATION

Specify: No. 99363-A1 Flow Control Valve.

DIMENSIONS

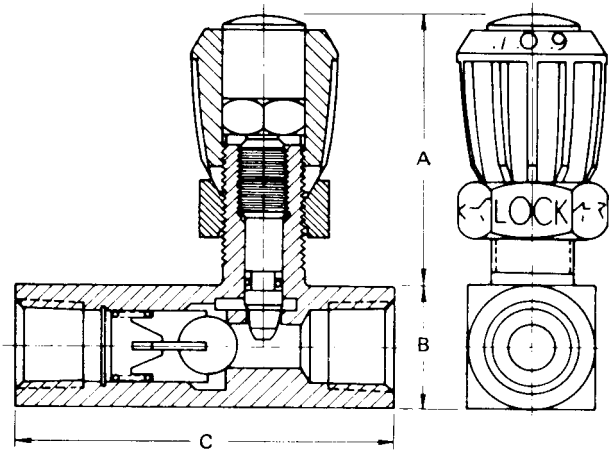

A Open	A Closed	B (Square)	C
1-5/8	1-15/32	5/8	1-15/16

Figure 1

Schneider
Electric Systems USA, Inc

1602 Mustang Dr
Maryville, TN 37801
Ph (865) 981-3100
FX (865) 981-3168