

Pressure Sensor No. 84372-Series

GENERAL DESCRIPTION

The patented* No. 84372-Series Pressure Sensor contains a weatherproof, snap-acting valve operated by pressure variation around the integral sensing element. Depending upon model used, it vents or blocks a pneumatic signal when the setpoint is reached and is available with either automatic or manual reset. The sensor has adjustable differential (auto reset versions only) and setpoint, provision for piped vent operation, and is field reversible. Setpoint is virtually unaffected by control pressure change or, in the case of piped vent versions, vent backpressure change. In the auto reset versions reset differential can be changed without shifting setpoint.

For correct operation, control pressure must be provided thru a .032" (.81 mm) diameter or smaller orifice.

* Patent 3.986,524

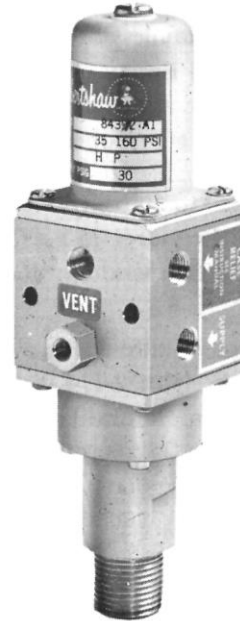

MODELS AVAILABLE



84372-A, C Series
 Vents on Increase
 (Direct Acting)



84372-B Series
 Closes Vent on Increase
 (Reverse Acting)

J.I.C. Symbols

TABLE I

SUFFIX	DESCRIPTION	RESET
A	Direct Acting - Vents on increase	Auto
B	Reverse Acting - Closes vent on increase	Auto
C	Direct Acting - Vents on increase	Manual

TABLE 2

SUFFIX	SETPOINT RANGE - PSI (bar)
1	35 to 160 (2.413 to 11.031)
2	80 to 400 (5.516 to 27.58)
3	200 to 1000 (13.79 to 68.95)
4	500 to 1750 (34.47 to 120.66)

See Page 2 for SPECIFICATIONS.

ORDERING INFORMATION

Specify:

1. Model
2. Control Pressure - If not specified, sensor is set using 30 psi (2.068 bar).
3. Setpoint - If not specified, set at minimum.
4. Differential (Automatic Reset models only) - If not specified, set at standard.
5. Tagging Information

Reset Differential Range: See graph corresponding to instrument model numbers.

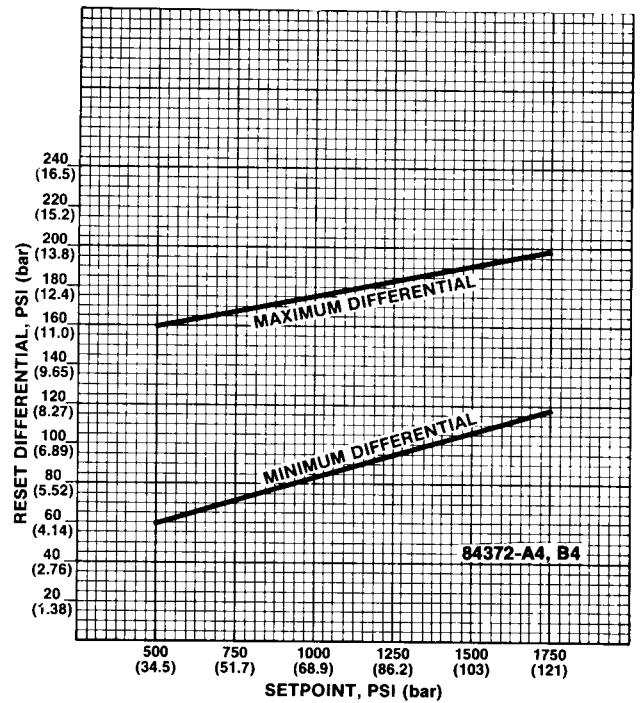
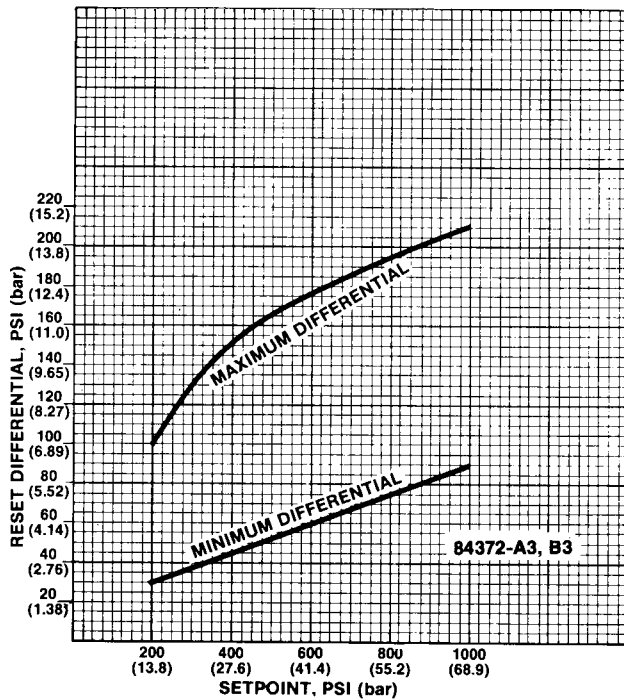
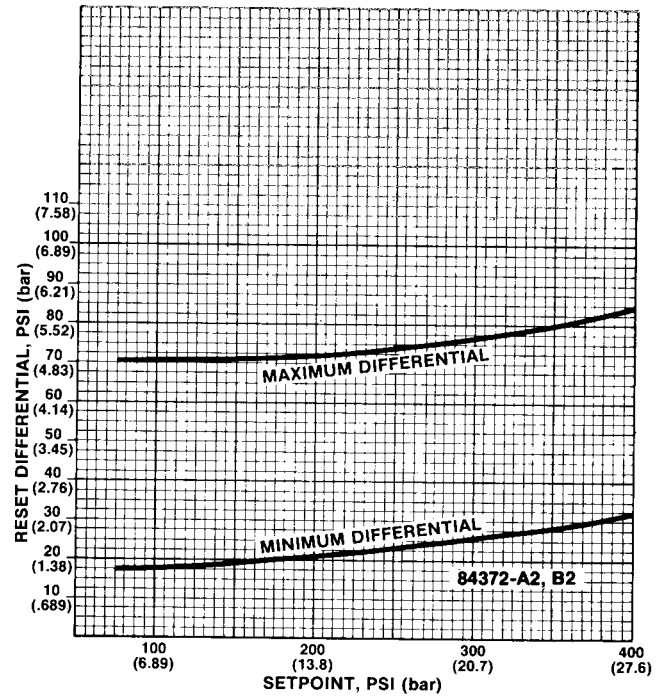
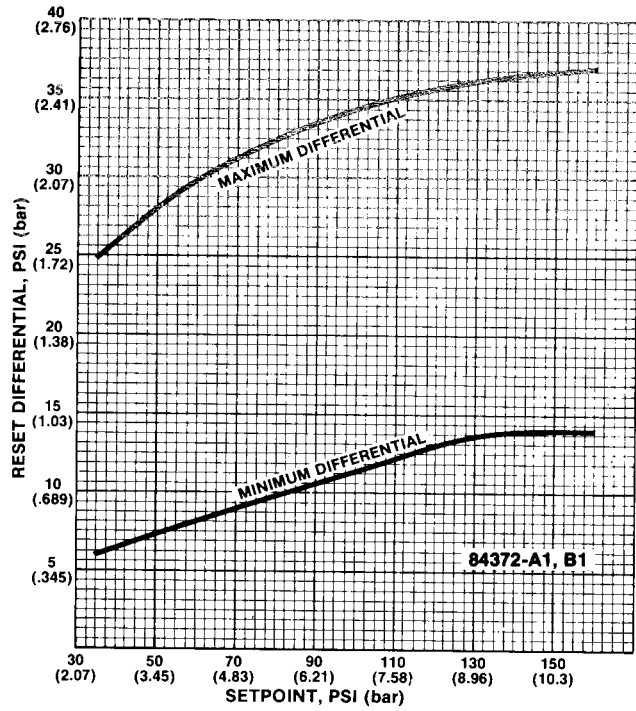

INSTALLATION (See Figure 1)

MOUNTING

The No. 84372-Series Pressure Sensor may be mounted in any position, although vertical (upright) is recommended. It should be securely mounted on the panel or other suitable surface to prevent excessive vibration using the two 7/32" (5.53 mm) diameter holes in the housing assembly. A 1/8"-27 NPT female process connection is provided for this type of mounting. The sensor also has a 1/2"-14 NPT connection for manifold mounting.

CAUTION: When installing the manifold-mounted sensor, screw into pipe or vessel using the wrench flats only. Turning by the housing will cause permanent damage to the sensor.

If the measured variable is a liquid, consideration should be given to the level of the liquid. Since an error in calibration could be caused by the weight of a body of liquid acting on the measuring assembly, it might be necessary to adjust the calibration to compensate for this constant weight (See ADJUSTMENTS).

If the sensor is out of doors or in any way exposed to water during cleaning, etc., it should be mounted in a position which will prevent water entry into the valve or spring housings. Water trapped in the housing will impair operation and could freeze during winter months. Vent openings should have fittings installed turned down. The 1/8"-27 NPT connection can be used for piped vent operation if gas is used.

CONNECTIONS:

The sensor has three 1/8"-27 NPT connections: one for control pressure, one for vent pressure, and one for case relief pressure.

CAUTION: Do not pipe or plug case relief connection. The vent pressure connection from the sensor cannot be used as a supply or control source for any other equipment. Vent backpressure should be held to as low a level as possible.

The control port pressure must be provided thru a .032" (.81 mm) diameter or smaller orifice using 1/4" (6.35 mm) or 3/8" (9.53 mm) O.D. tubing not exceeding 100 ft. (30.5 m) in length. Using excessive lengths or other than the specified tubing is not recommended.

Tubing and fittings used to connect the sensor must be free of chips, dirt, moisture or other foreign matter.

It is recommended that a non-hardening, "anti-seize" type thread compound be applied to the second or third male thread in moderate amount. Do not allow any compound to be deposited inside the sensor. Thread sealing tape is not recommended.

If the sensor is used with a liquid process pressure, entrapped air in the tubing connected to the measuring assembly should be vented. This can be accomplished by bleeding the fitting connection installed at the sensing element.

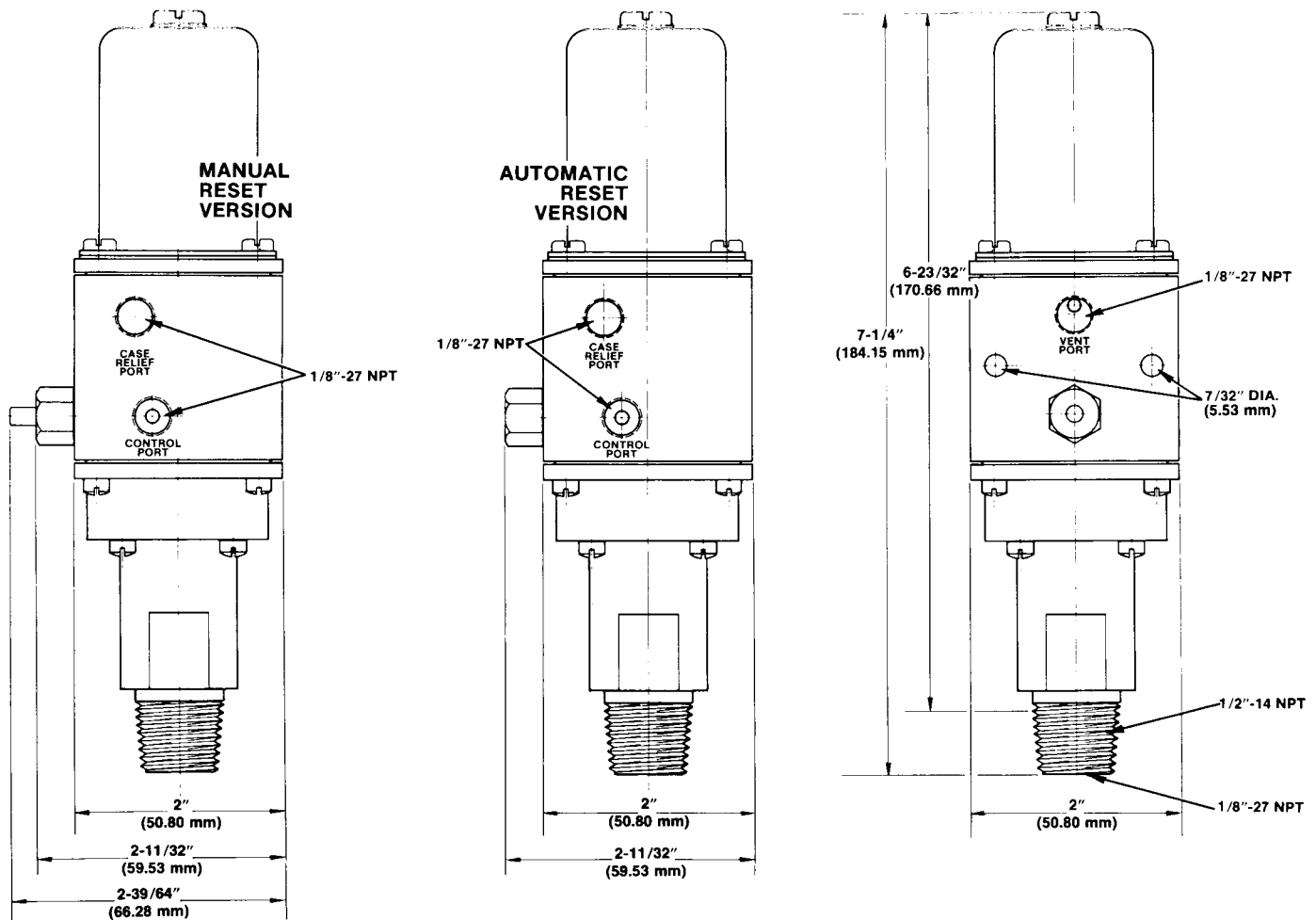

Figure I
Direct Acting Shown

OPERATION (See Figure 2)

In the direct-acting models, process pressure pushes the stem against the range spring. The bellows head moves toward the range spring and compresses the bellows due to the inlet port (control) pressure. When the process pressure reaches the range spring setpoint, the stem pushes the sleeve off its O-ring seat. Inlet pressure flows past the O-ring and into the inside cavity of the bellows. This equalizes the outside to inside pressure of the bellows and allows the spring-action of the bellows to "snap" the bellows head toward the reset and differential adjustment screw. The inlet port pressure is thus vented past the diaphragm seat and out the vent port.

With the lowering of process pressure below set-point, the range spring forces the stem and sleeve

toward the bellows head. In the automatic reset models, the bellows head is stationary at this time against the reset and differential screw. This stationary position allows the sleeve to seat itself on the O-ring after sufficient process pressure is lost. In the manual reset models, the reset button must be pressed to force the bellows head toward the sleeve to allow seating as the sleeve itself cannot move a distance sufficient to contact the O-ring. This sleeve and O-ring contact causes the loss of inlet port pressure inside the bellows. The bellows head moves toward the range spring and resets the sensor.

Reverse-acting models vent on a decrease in process pressure.

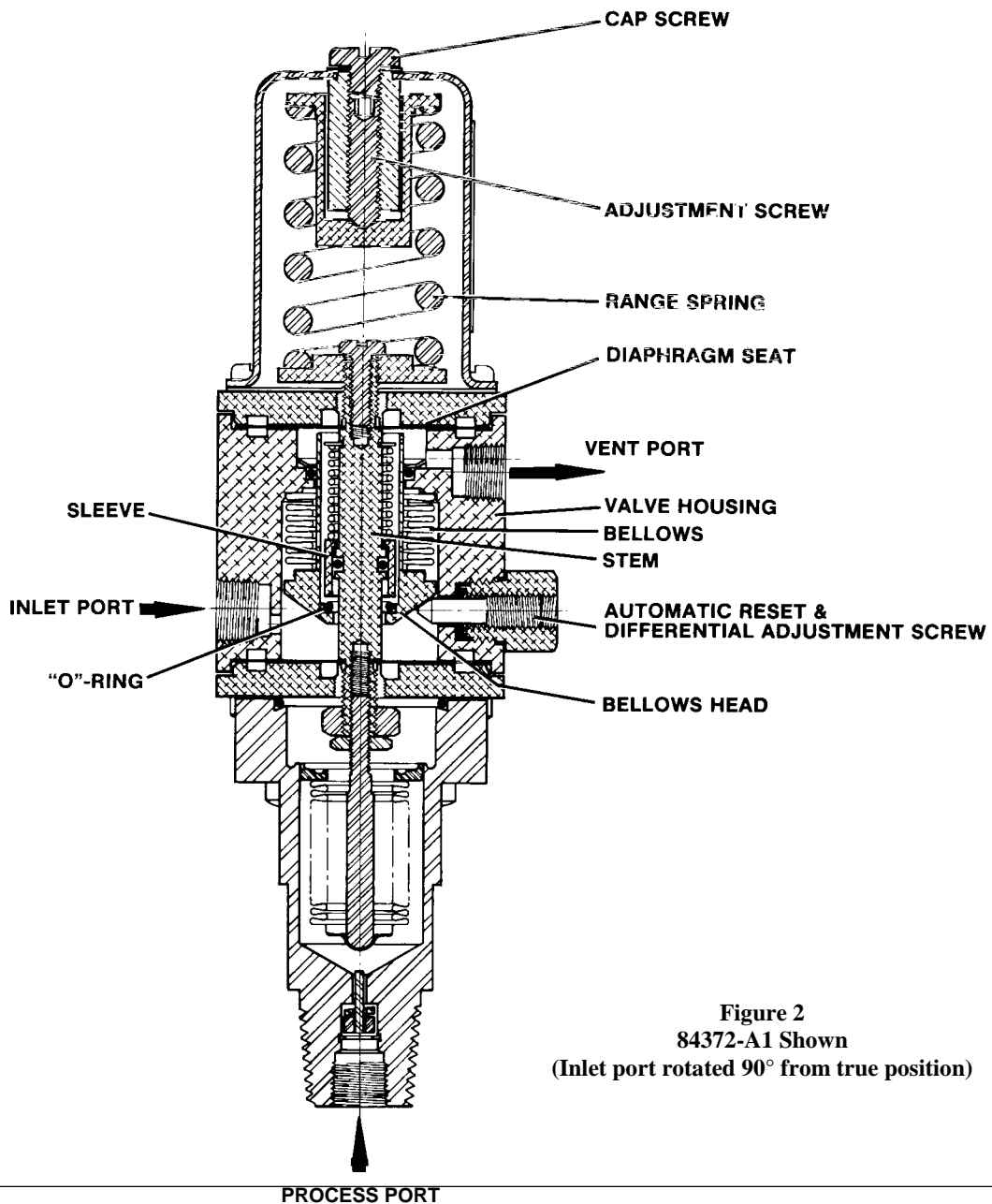

Figure 2
84372-A1 Shown
(Inlet port rotated 90° from true position)

MAINTENANCE (See Figure 4)

WARNING: USE CARE WHEN DISASSEMBLING, SPRING FORCES PRESENT.

CAUTION: Do not subject O-rings, gasket or diaphragms to cleaning fluid, acetone, or any halogenated hydrocarbons such as degrease liquids, etc. Clean only with a soft, dry cloth. Metal parts can be cleaned with a suitable solvent then dried thoroughly before reassembly.

*NOTE: Threads on screw (detail 8), diaphragm clamps, spring housing screws (detail 11), bushing, flange screws (detail 22), and pressure assembly, screws (detail 26) should have Loctite Sealant "H" or equivalent applied before reassembly. See * below.*

SNUBBER ASSEMBLY

Remove retaining ring (detail 35), snubber assembly, and lock washer (removal of pressure assembly from sensor may be required to remove snubber from assembly - for removal see Pressure Assembly Maintenance section). Replace defective snubber assembly and reassemble. Recalibrate as necessary.

PRESSURE ASSEMBLY

Remove four screws (detail 26), O-ring (detail 23) and pressure assembly. If desired, remove snubber assembly from defective pressure assembly (see instructions above) and reassemble into replacement pressure assembly. Otherwise, assemble a new snubber assembly into the replacement pressure assembly. Reassemble* and recalibrate.

BUSHING

To replace bushing O-ring (detail 19), remove bushing and replace defective O-ring. Reassemble* and replace in housing assembly. Recalibrate differential if unit is an automatic reset model.

HOUSING ASSEMBLY AND STEM

Remove cap screw and turn adjustment screw (detail 6) counterclockwise to bring the range spring to free length. Remove the four screws (detail 11), spring housing, spring seat (detail 4), range spring, and gasket. Remove the pressure assembly as previously described. As applicable, proceed with the Direct- or Reverse Acting instructions below.

Direct Acting

Prevent the spring seat (detail 9) from rotating and back the lock nut away (counterclockwise) from the nut several turns. Preventing the spring seat (detail 9) from rotating, remove the adjusting screw and nut. Remove the four screws (detail 22) and flange (detail 21).

Prevent the spring seat (detail 9) from rotating and remove the exposed diaphragm clamp. Remove the exposed diaphragm. Remove the stem by pulling the flange (detail 13) from the valve housing.

To replace O-ring (detail 36) on stem, prevent spring seat (detail 9) from rotating and remove screw (detail 8). Prevent stem from rotating and remove spring seat (detail 9) and flange (detail 13). Proceed with instructions designated Direct and Reverse Acting below.

Reverse Acting.

Prevent the nut from rotating and remove the screw (detail 8) and spring seat (detail 9). Remove the flange (detail 13).

Prevent the nut from rotating and remove the exposed diaphragm clamp. Remove the exposed diaphragm.

Remove the four screws (detail 22). Remove the stem by pulling the flange (detail 21) from the valve housing.

To replace O-ring (detail 36) on stem, prevent the nut from rotating and back the lock nut away (counterclockwise) from the nut several turns. Remove the adjusting screw, nut, and flange (detail 21). Proceed with instructions designated Direct and Reverse Acting below.

Direct and Reverse Acting

Remove remaining diaphragm clamp and diaphragm. Remove retaining ring (detail 37), spring (detail 39), and sleeve. Remove defective O-ring (detail 36) and replace. Reassemble sleeve, spring (detail 39) and retaining ring (detail 37).

To replace O-ring (detail 31) in valve housing, remove retaining ring (detail 30) and defective O-ring (detail 31). Replace O-ring, then retaining ring.

To replace O-ring (detail 32) which seats against the sleeve, remove the defective O-ring with a knife or other sharp-pointed tool. Carefully remove any residue and clean area from where O-ring was removed with a suitable solvent. Dry thoroughly. Place a few drops of liquid Viton (Pelmor Laboratories' PLV-2000 or equivalent) on the sealing area just cleaned. Take the replacement O-ring, remove from it any dirt, dust, or foreign matter, and bond it to its seating area. Allow to cure for one or more hours.

With all O-rings, diaphragms, gaskets, and defective parts replaced, reassemble as follows:

On models with automatic reset, turn differential adjustment screw into bushing clockwise until small end of bellows head is even with surface "D" - see figure 3.

(On models with manual reset, the reset plunger will need to be held depressed to obtain surface "D" contact as explained below).

Replace stem, diaphragms, and diaphragm clamps.* Tighten clamps hand tight. While holding each clamp with a wrench, tighten approximately $\frac{3}{4}$ turn more. Reassemble* balance of parts as shown in figure 3.

On models with manual reset, depress the reset plunger to maintain small end of bellows head and surface "D" contact while obtaining the following dimensions - see figure 3.

Apply approximately one pound force (4.45N) by finger at point "P." Turn spring seat to obtain dimension "A" - see Table 3. Lock spring seat in place with screw.*

With a gage in place to hold dimension "A," adjust adjusting screw to dimension "B" and nut to dimension "C" - see Table 3. Lock both in place with lock nut as shown in figure 3.

Release reset plunger on manual reset models and turn differential adjustment screw counterclockwise approximately $\frac{3}{4}$ turn on automatic reset models.

Reassemble* balance of parts and recalibrate sensor.

Field Reversal

To change the sensor from direct- to reverse-acting or vice versa, remove the spring seat (detail 9), adjusting screw, and nut from stem. Reset bellows head to surface "D" as explained in the Housing Assembly and Stem Maintenance section. Reassemble spring seat (detail 9), adjusting screw, and nut on appropriate end of stem using figure 3 as a guide. Reset dimensions "A," "B," and "C" and

reassemble as explained in the Housing Assembly and Stem Maintenance instructions. Recalibrate sensor when assembled.

ADJUSTMENTS (See Figure 4)

SETPOINT

1. Remove cap screw.
2. Apply operating control pressure to inlet port through a .032" (.81 mm) diameter or smaller orifice. Control pressure and orifice size must be the same as that used during normal operation.
3. Apply process pressure at desired setpoint to the process port.
4. Insert a 1/8" hex wrench into the adjustment screw and turn screw counterclockwise (clockwise for reverse-acting units) until the valve snaps open and sensor vents.
5. Check operation and trim as necessary.
6. Replace the cap screw.

DIFFERENTIAL (Applicable to Auto Reset Models only)

CAUTION: Sensor will not vent if differential adjustment screw is turned clockwise to its maximum insertion into the valve housing. Do not set differential below minimum recommended value as shown in graphs.

1. Apply operating control pressure to inlet port through a .032" (.81 mm) diameter or smaller orifice. Control pressure and orifice size must be the same as that used during normal operation.
2. Cycle measured pressure at the process port and adjust the differential adjustment screw until desired differential is obtained. Differential is increased by turning the screw counterclockwise.

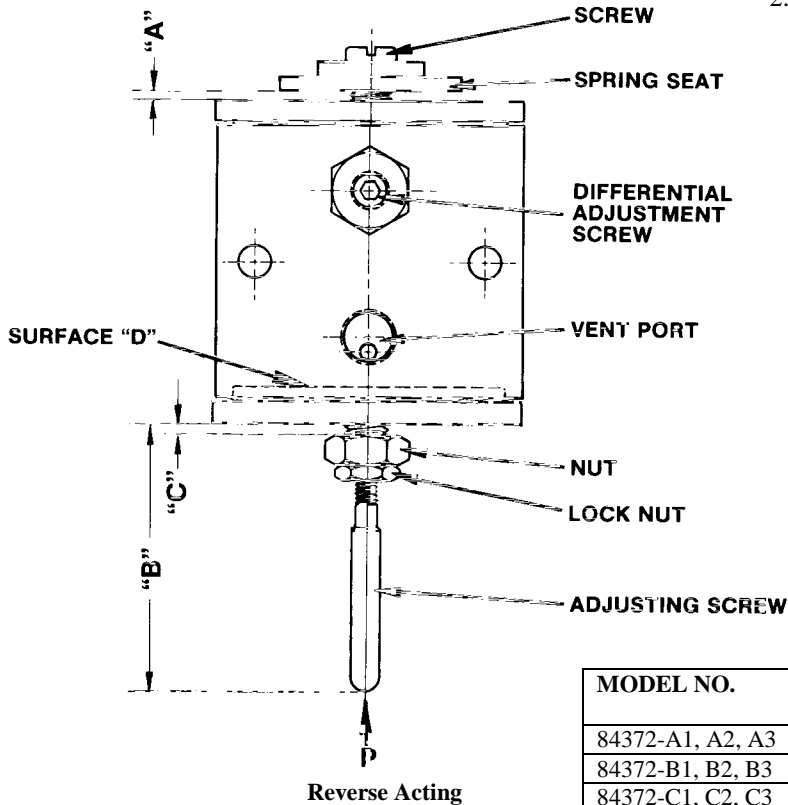
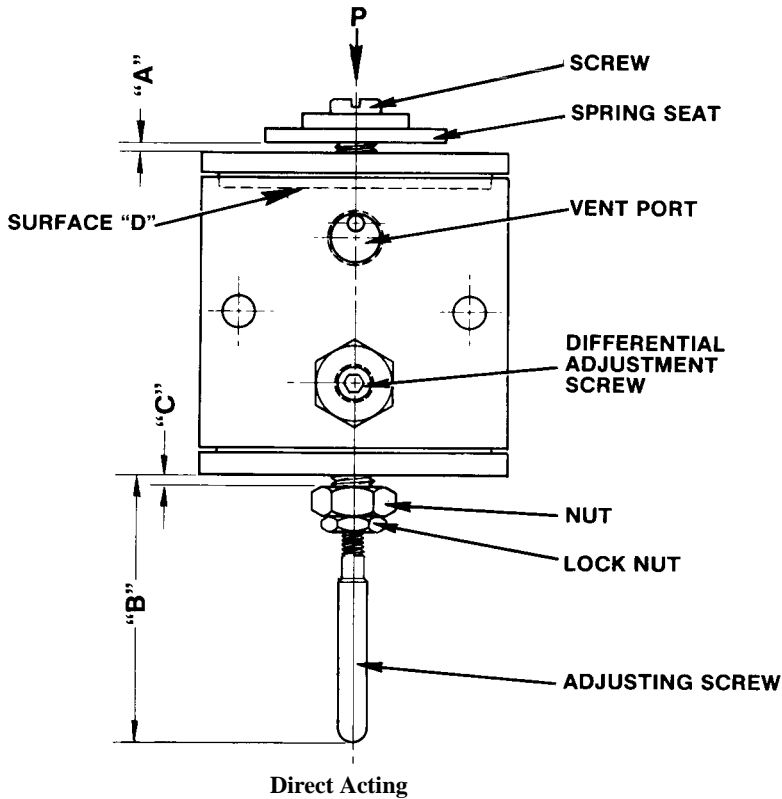

Figure 3

Table 3

MODEL NO.	DIM. "A" In. (mm)	DIM. "B" In. (mm)	DIM. "C" In. (mm)
84372-A1, A2, A3	.040 (1.016)	1.745 (44.33)	.010 (.254)
84372-B1, B2, B3	.010 (.254)	1.765 (44.83)	.040 (1.016)
84372-C1, C2, C3	.040 (1.016)	1.745 (44.33)	.010 (.254)
84372-A4, C4	.020 (.508)	1.765 (44.83)	.010 (.254)
84372-B4	.010 (.254)	1.765 (44.83)	.020 (.508)

PARTS LIST

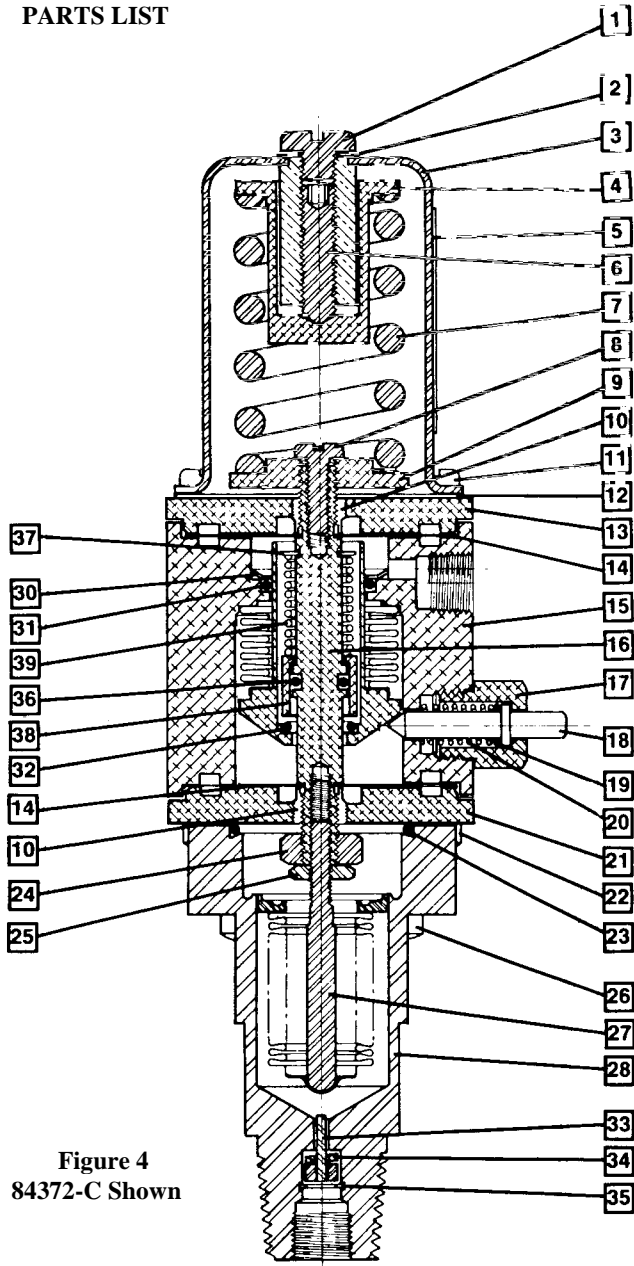

Figure 4
84372-C Shown

DOT. NO.	NO. REQ'D	DESCRIPTION	PART NO.
1	1	Cap Screw	33718-G0509
2	1	Washer	24425-A1
3	1	Spring Housing	84366-A1
4	1	Spring Seat	24557-B1
5	1	Name Plate	See table below
6	1	Adjustment Screw	24558-A2
7	1	Range Spring	See table below
8	1	Screw	33713-G1109
9	1	Spring Seat	33968-A2
10	2	Diaphragm Clamp	33969-A1
11	4	Screw	33713-G1309
* 12	1	Gasket	33971-A1
13	1	Flange	33966-B1
* 14	2	Valve Diaphragm	33972-A1
15	1	Housing	84364-A1
16	1	Stem	33973-A1
17	1	Bushing	See table below
18	1	Reset Plunger	See table below
* 19	1	"O"-Ring	36240-V0007
20	1	Spring	See table below
21	1	Flange	33966-B1
22	4	Screw	33713-H1709
* 23	1	"O"-Ring	36240-C0023
24	1	Nut	36602-E1809
25	1	Lock Nut	36602-A1309
26	4	Screw	Not used
27	1	Adjusting Screw	33985-A1
28	1	Pressure Assembly	See table below
29	1	Differential Adjustment Screw (No shown)	See table below
* 30	1	Retaining Ring (Included in Det. 15)	36605-B2
* 31	1	"O"-Ring (Included in Det. 15)	36240-V0016
* 32	1	"O"-Ring (Included in Det. 15)	36243-V0012
33	1	Snubber Assembly	84386-A1
34	1	Lock Washer	36600-J0510
* 35	1	Retaining Ring	36605-A5
* 36	1	"O"-Ring	36240-V0010
* 37	1	Retaining Ring	36605-Q9
38	1	Sleeve	33974-A2
39	1	Spring	33975-A1

NOTE: For complete kit containing all O-rings, gaskets, diaphragms and retaining rings to service one unit, order Repair Kit No. 82665-G1. Kit includes details marked *.

TABULATION

MODEL NO.	DET. 5	DET. 7	DET. 17	DET. 18	DET. 20	DET. 28	DET. 29
84372-A1	33970-B31	33980-D1	33964-A2			98952-B1	33963-A1
84372-A2	33970-B32	33980-E1	33964-A2			98952-B2	33963-A1
84372-A3	33970-B33	33980-F1	33964-A2			98952-B3	33963-A1
84372-A4	33970-B34	33980-B1	33964-A2			98952-B3	33963-A1
84372-B1	33970-B39	33980-D1	33964-A2			98952-B1	33963-A1
84372-B2	33970-B40	33980-E1	33964-A2			98952-B2	33963-A1
84372-B3	33970-B41	33980-F1	33964-A2			98952-B3	33963-A1
84372-B4	33970-B42	33980-B1	33964-A2			98952-B3	33963-A1
84372-C1	33970-B47	33980-D1	33964-B2	33962-A2	33965-A1	98952-B1	
84372-C2	33970-B48	33980-E1	33964-B2	33962-A2	33965-A1	98952-B2	
84372-C3	33970-B49	33980-F1	33964-B2	33962-A2	33965-A1	98952-B3	
84372-C4	33970-B50	33980-B1	33964-B2	33962-A2	33965-A1	98952-B3	



1602 Mustang Dr
Maryville, TN 37801
Ph (865) 981-3100
FX (865) 981-3168

Q-3107 (2/19)

Printed in U.S.A.