

**PRODUCT SPECIFICATION I-1285-P & Q**

**Temperature Regulator  
I-1285-P & Q  
Series**



**General Description**

The I-1285-P & Q Series Temperature Regulators are compact, self-contained and self-powered, three-way control valves especially adaptable to control of water and lubricating oil temperatures on internal combustion engines. The POWER PILL® element, located inside the poppet assembly, responds to the temperature of the medium surrounding it and provides the force necessary to position the poppet as the temperature of the liquid passing through the valve changes. Temperature regulation is achieved by the proportional action of the three-way valve which varies the amount of medium through or bypassing the cooler to maintain the desired temperature. Operation of the POWER PILL® elements is unaffected by pressure changes in the system.

The POWER PILLS are factory-set for the specified control temperature and are not manually adjustable. By exchange of POWER PILL® elements the operating temperature may be changed in a very simple manner. Since all internal parts lift out with the valve bonnet, it is not necessary to remove the valve from the piping.

**Specifications**

**A. CONSTRUCTION**

- Valve Body** .....Cast steel with 150 lb. ANSI Flanges.
- Trim** .....Brass poppet with integral Steel seating surfaces.
- Poppet Seal** .....Split Buna-N "O"-ring (General Purpose)
- Dimensions** .....See Figure 1

**B. OPERATING RANGES**

Available temperature ranges are tabulated below. The maximum valve body rating is 150 psi at 250° F.

*CAUTION: Do not exceed maximum temperature / pressure rating.*

**C. MODELS AVAILABLE \***

MODEL NO.		I-1285-P 8			
CODE	SIZE	NORMAL OPERATING TEMPERATURE AT MID-STROKE, °F			
		STANDARD		SPECIAL	
P	3"	CODE	TEMP.	CODE	TEMP.
Q	4"	18	120	24	60
		1	130	16	75
		15	140	22	80
		4	150	20	90
		5	155	19	100
		10	160	25	110
		11	165	2	135
		12	170		
		21	175		
		13	180		
		8	185		
		17	190		
		23	200		

\*NOTE: For cast brass valve body, refer to I-1285-B through G Series.

## INSTALLATION

### A. GENERAL

Prior to installation, the valve body and parts should be checked to determine if any damage occurred in shipment. Any damage should be reported to the shipper as soon as possible. Foreign matter which may have entered the valve during packing or shipment should be removed.

### B. LOCATION

The I-1285 may be installed indoors or out, provided the liquid to be controlled does not freeze. Temperature regulators should be installed as near as possible to the unit being controlled, and a pipeline strainer should be installed upstream.

### C. POSITION

Although these valves will operate in any position, the best performance is achieved in the vertical upright position (E port down). When the four, five, or six inch regulators are to be installed up-side-down, the factory should be notified so that a special load spring may be supplied. (See Parts List.)

### D. SERVICE

Unless otherwise specified on the order, regulators are shipped with a general purpose (Buna-N) split "O"-ring installed.

Whenever synthetic\* lube oils or special coolants are used, the factory should be consulted to determine compatibility with split "O"-ring material.

*\*Not recommended for use with ester base synthetic lubricant.*

Valve Model	Size In.	Dimension								
		A	B	C	D	F	G	H	M	X
I-1285-P	3"	11-3/16	7-1/2	13/16	10-1/2	4	3/4	6	6-3/4	10
I-1285-Q	4"	12-1/2	9	15/16	15-7/8	8	3/4	7-1/2	8-9/16	12

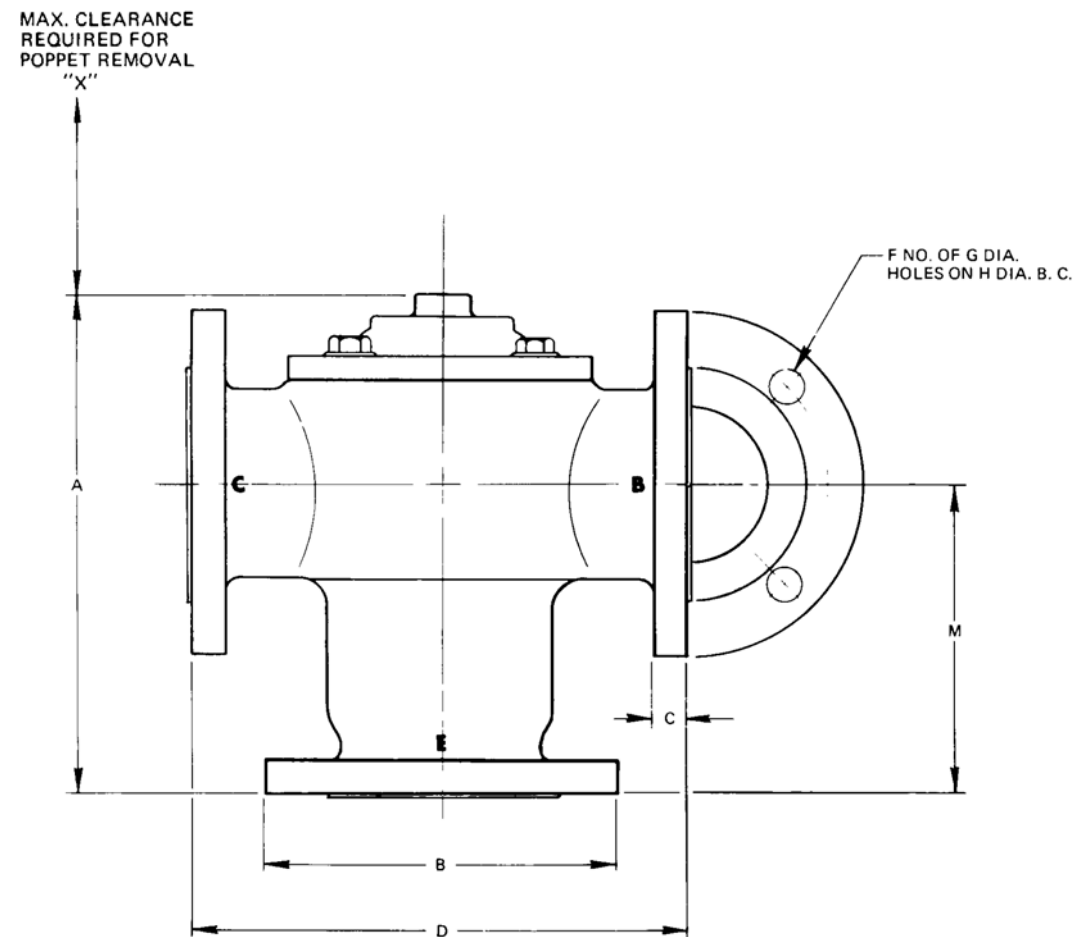

Figure 1

PARTS LIST (Cont'd)

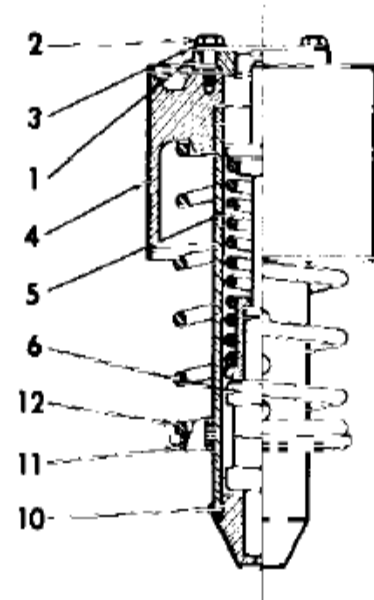

Figure 5  
3" & 4" Sizes

DETAIL NO.	DESCRIPTION	No. Req'd	I-1285-P 3"	No. Req'd	I-1285-Q 4"
*All	Complete Poppet Assembly	1	82157-S10*	1	82157-S20*
4	Poppet & Pipe Assy.	1	82159-C4	1	82159-A3
5	Top Spring & Stem Assy.	1	82158-A1	1	82158-A1
*6	Thermo. Assembly	2	96995-A*	2	96995-A*
7	Spacer	-		-	
8	Spring	-		-	
9	Bottom Spring & Stem Assy.	-		-	
10	Drive Screw	1	25033-A1	1	25033-A1
11	Spring Retainer	1	31105-D1	1	31105-D1
†12	Load Spring	1	19863-A1	1	19863-A1

\* Add suffix number to thermos Assembly and for Poppet Assembly per range code on Page 1.

EXAMPLE: Thermo Assembly 96995A11 for 165°F setpoint.

†Springs for inverted valve service

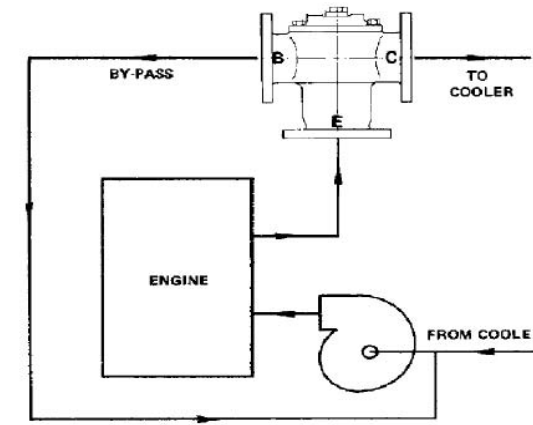

PIPING SCHEMATIC - Used as diverting valve to control temperature leaving engine, most common application.

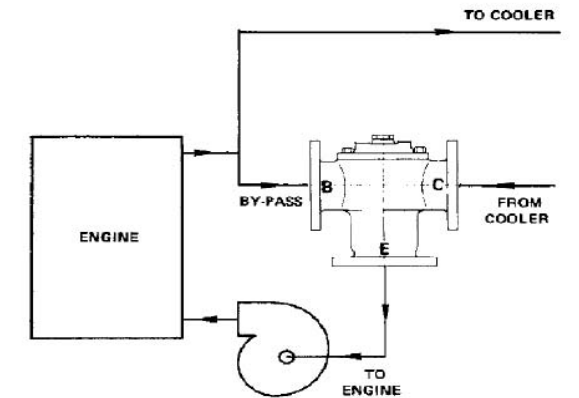
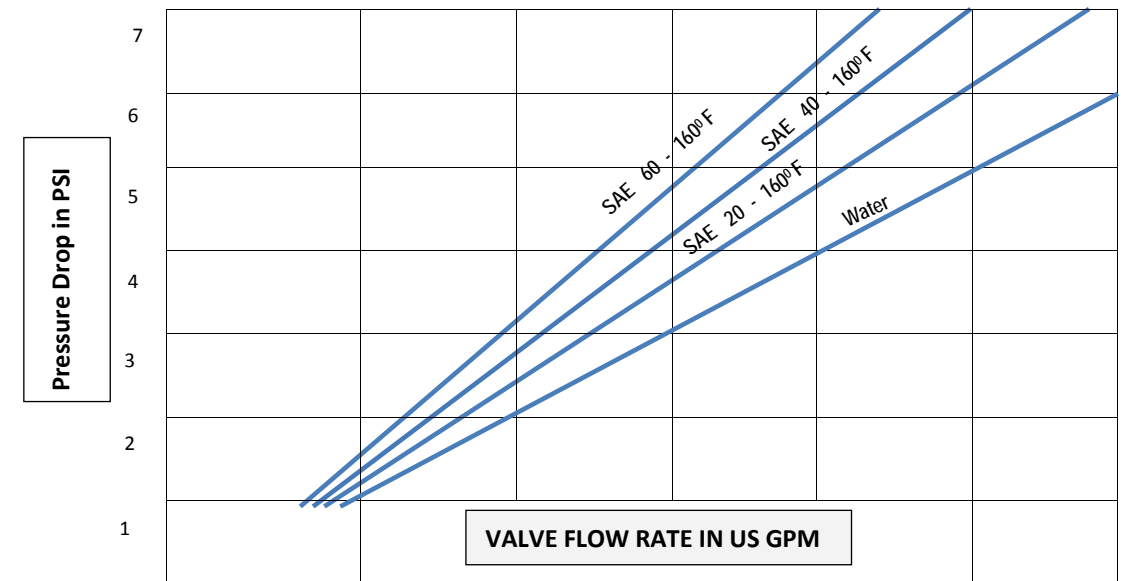

Figure 2 PIPING SCHEMATIC - Used as blending valve to control temperature entering engine.

OPERATION

With low temperature liquid surrounding the POWER PILL, the poppet is in the upward position which connects ports "E" and "B". As the temperature increases, the POWER PILL stem extends forcing the poppet downward. When the temperature reaches the control point of the regulator, the valve will be at mid-stroke.

If the temperature continues to increase, the poppet will continue to move downward until the by-pass port (B) is completely closed off. (See Figure 4.) FLOW COEFFICIENTS: Table below indicates the flow in U.S. G.P.M. at different pressure drops. Cv Coefficients are listed in column 1 under 1 psi pressure drop (water)



<b>3"</b>	<b>C- Cooler Port</b>	<b>107</b>	<b>151</b>	<b>188</b>	<b>214</b>	<b>239</b>	<b>262</b>
	<b>B- Bypass Port</b>	<b>116</b>	<b>164</b>	<b>201</b>	<b>232</b>	<b>260</b>	<b>284</b>
	<b>E- Mid Stroke</b>	<b>113</b>	<b>188</b>	<b>232</b>	<b>266</b>	<b>297</b>	<b>326</b>
<b>4"</b>	<b>C- Cooler Port</b>	<b>262</b>	<b>370</b>	<b>454</b>	<b>524</b>	<b>586</b>	<b>641</b>
	<b>B- Bypass Port</b>	<b>243</b>	<b>343</b>	<b>421</b>	<b>486</b>	<b>544</b>	<b>595</b>
	<b>E- Mid Stroke</b>	<b>324</b>	<b>457</b>	<b>561</b>	<b>648</b>	<b>725</b>	<b>794</b>

NOTE 1: Cv coefficients coincide with figures in first column.

NOTE 2: Data on "Mid-Stroke" shows total flow through inlet with valve in mid position.

NOTE 3: Normally for engine application, valve should be sized for total flow through cooler port, based on a pressure drop of 2-5 psi (incl.).

NOTE 4: Total leakage through seats and web, approximately 2% or less of total flow with O-Ring removed.

## MAINTENANCE

### A. RECOMMENDED SPARE PARTS

The following parts should be kept on hand for maintenance purposes:

1. Split "O" ring seal.
2. Replacement power pills.
3. Bonnet gasket.

### B. TROUBLE SHOOTING

If valve fails to make required stroke as temperature exceeds control point, check for:

1. Foreign matter interfering with poppet travel.
2. Swollen or damaged split "O" -ring seal. (See "Service," Page 2.)
3. Power pill failure.

If valve fails to return to stroke as temperature drops below control point, check for:

1. Foreign matter interfering with poppet travel.
2. Swollen or damaged split "O"-ring seal. (See "service," Page 2.)
3. Damaged load spring.
4. Power pill failure.

#### Excessive internal leakage between ports:

1. Damaged or worn out split "O"-ring seal. (See "Service," Page 2.)
2. Damaged or uneven valve seats.
3. Poppet not making complete stroke.

### C. REPAIR

**WARNING: Disassemble carefully - spring load forces present.**

#### Replacing power pill elements:

1. Remove bonnet and poppet assembly from valve and place on wooden blocks. (See Figure 3.)
2. Loosen the bolts on top of the poppet and remove the stem and retainer by lifting upward.
3. Power pills and overrun assemblies may now be removed.
4. Reassemble as shown in Figures 4 through 5, depending on valve size.

#### Replacing split "O" -ring seal:

1. Remove bonnet and lift out the entire poppet assembly.
2. Remove old split "O"-ring and replace with a new one (See "Service," Page 2.)
3. Replace poppet assembly, taking care not to cut or pinch ring.

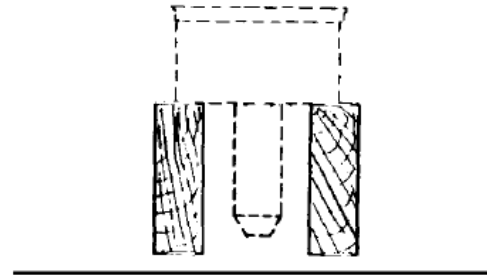

Figure 3

### D. ADJUSTING THE I-1285

1. Rest the bottom of the poppet on blocks. (See Figure 3.)
2. Loosen stem locknut on inside of bonnet.
3. Place bonnet on the poppet assembly and adjust the stem until the poppet just touches seating surface on the bonnet.
4. Turn the stem into the bonnet one half to one turn so that the poppet is securely seated.
5. Tighten locknut and bend the tab on the lock washer.
6. The poppet and bonnet assemblies are now ready to install in the body.

### E. REPAIR PARTS

For replacement part numbers, consult the parts list, Pages 5 and 6. when ordering give complete model number, spare part name and number, with quantity required.

#### Ordering Information:

Specify Model No. including suffix.

## PARTS LIST

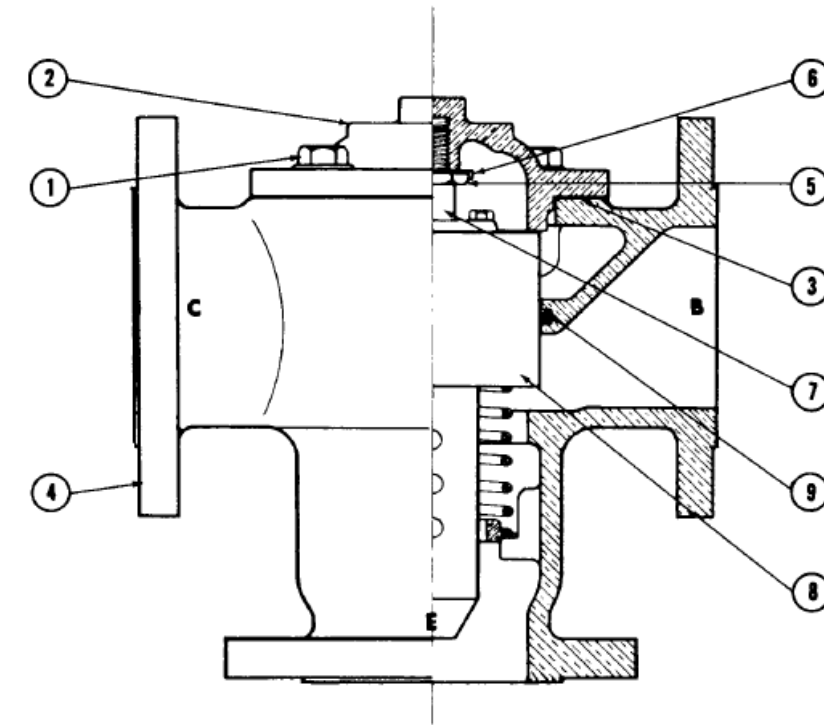

Figure 4

DETAIL NO.	DESCRIPTION	No. Req'd	I-1285-P 3"	No. Req'd	I-1285-Q 4"
1	Cap Screw	4	36629-E2823	8	36629-E2823
2	Bonnet & Seat Ring	1	29429-C1	1	20189-B1
3	Gasket	1	39385-F1	1	39385-F2
4	Valve Body & Seat Ring	1	81710-B1	1	84867-A1
5	Locknut	1	20195	1	20195
6	Lock Washer	1	20194	1	20194
7	Stem	1	20192	1	20192
8	Poppet Assembly	1	See Fig. 5	1	See Fig. 5
9	Split "O"-Ring General Purpose	1	22777	1	22777-C1